

PREVENTIVE MAINTENANCE INSTRUCTIONS

FOR RSP-2150, RSP-2150i, AND SCRIBE 5 DATA STORAGE SUBSYSTEMS

These instructions are provided with the Intermediate Level Maintenance Kit and describe the preventative maintenance procedures for the Data Storage Subsystem's Transport assembly.

1. SCHEDULED PROCEDURES

Preventive maintenance is broken down into three different classes as follows:

- **Operator's Preventive Maintenance:** These are the regularly scheduled inspections and cleaning needed to maintain the Data Storage Subsystem. Refer to Section 3 in the appropriate User's Guide for Operator's Preventive Maintenance procedures.
- **Intermediate Level Preventive Maintenance:** This is regularly scheduled cleaning and lubrication needed to maintain the Data Storage Subsystem. Also included are scheduled replacement of key items that are subject to failure over time. Table 1 contains the list of items, recommended time intervals, and a reference to the instructions in this manual that contain the procedures. The recommended time intervals are to be considered maximum. Heavy usage, adverse conditions, or local maintenance procedures may dictate more frequent maintenance. Intermediate Level Preventive Maintenance procedures are provided in this instruction sheet, and must be performed by a trained service technician.
- **Depot Level Preventive Maintenance:** This is the scheduled replacing of key items that are subject to failure over time. Table 1 contains the list of items, and recommended time intervals. The recommended time intervals are to be considered maximum. Heavy usage, adverse conditions, or local maintenance procedures may dictate more frequent inspections. Depot level maintenance can only be performed at a qualified depot facility. All depot level repair can be performed on an exchange/repair basis with service depots. Contact your service representative for the location of available depot facilities.

NOTE

A Depot Maintenance Appendix is available only to persons that have completed Metrum's depot level service training course. If you have not completed the service training course, or if the appendix is not available, contract your distributor for service, or return the Transport Assembly to Metrum for maintenance.

WARNING

Always disconnect power from the Data Storage Subsystem before performing any preventive maintenance.

2. MATERIALS REQUIRED

The common materials required to perform the maintenance procedures that follow include a metric Phillips head screwdriver, needle nose pliers, and disposable towels.

In addition to the common materials, this Intermediate Level Maintenance Kit (Metrum P/N 16823295-002) is also required for intermediate level preventive maintenance. This maintenance kit contains the following items:

- Compressed air duster (canned air).
- Cloth swabs.
- Cotton gloves.
- ESD strap (disposable).
- Grease applicator stick.
- Head cleaning cloth.
- Head cleaning solution.
- Lint-free soft cloth.
- Molytone grease MOR265.
- Replacement internal cleaning roller.
- Scanner head chamois cleaning swabs.
- Spindle oil (high quality).

Table 1. Preventive Maintenance Procedures

INTERVAL	ITEM	ACTION	MANUAL REF
50-hours head time Customer Maintenance	Transport tape path	Clean	See Section 3 in the User's Guide for procedure.
	External case	Clean	See Section 3 in the User's Guide for procedure.
1000-hours head time or 20,000 cartridge loads Intermediate Level Maintenance	Transport assembly	Lubrication	See paragraph 3.
	Transport tape path	Cleaning	See paragraph 4.
	Head cleaning roller	Replace	See paragraph 5.
2000-hours head time or 50,000 cartridge loads Depot Level Service	Head cleaning roller	Replace	See paragraph 5.
	Upper scanner	Replace	Contact your service representative.
	Capstan pinch roller	Replace	Contact your service representative.
	Main brakes	Replace	Contact your service representative.
	Takeup/Supply Reels	Replace	Contact your service representative.
	Pinch Cam	Replace	Contact your service representative.
	Loading Belt	Replace	Contact your service representative.
	Transport tape path	Alignment	Contact your service representative.
6000-hours head time or 100,000 cartridge loads Depot Level Service	Lower scanner	Replace	Contact your service representative.
	A/C head	Replace	Contact your service representative.
	Erase head	Replace	Contact your service representative.
	Incline bases	Replace	Contact your service representative.
	Mode switch	Replace	Contact your service representative.
	Reel motor assembly	Replace	Contact your service representative.
	Transport tape path	Alignment	Contact your service representative.

3. TRANSPORT LUBRICATION

The recommended lubrication/cleaning interval for the Data Storage Subsystem transport is once every 1,000 hours of record/reproduce time (or 20,000 cartridge loads) using the recommended maintenance kit described previously. The transport may need to be lubricated/cleaned more often as conditions warrant (dependent on operating environment, tape quality, etc).

The transport assembly is lubricated before cleaning using the following instructions. Figures 1, 2, and 3 illustrate transport lubrication.

CAUTION

This equipment contains ESDS devices. Proper ESDS device handling procedures must be followed. Refer to the ESDS DEVICE HANDLING information at the front of the User's Guide for more information.

CAUTION

AC Head Assembly alignment is very critical and fragile. When performing maintenance on the Transport Assembly, make certain that the AC Head Assembly is not moved.

1. Verify that a data cartridge is not loaded (eject if necessary).
2. Set the Data Storage Subsystem POWER switch to OFF and disconnect all power and interconnecting cables.
3. If rack mounted, remove the Data Storage Subsystem from the rack and place on a hard flat surface.
4. Remove the top cover (20 screws).
5. Remove the following cables from the Head Amplifier Assembly.
 - 6-pin cable on left side
 - 8-pin cable on right side
6. Remove the following cables from the Transport Control Circuit Card.
 - 40-pin ribbon cable towards front
 - 8-pin cable towards rear
7. Remove Bit Synchronizer Circuit Card.
8. Loosen two captive screws and remove Transport Assembly.

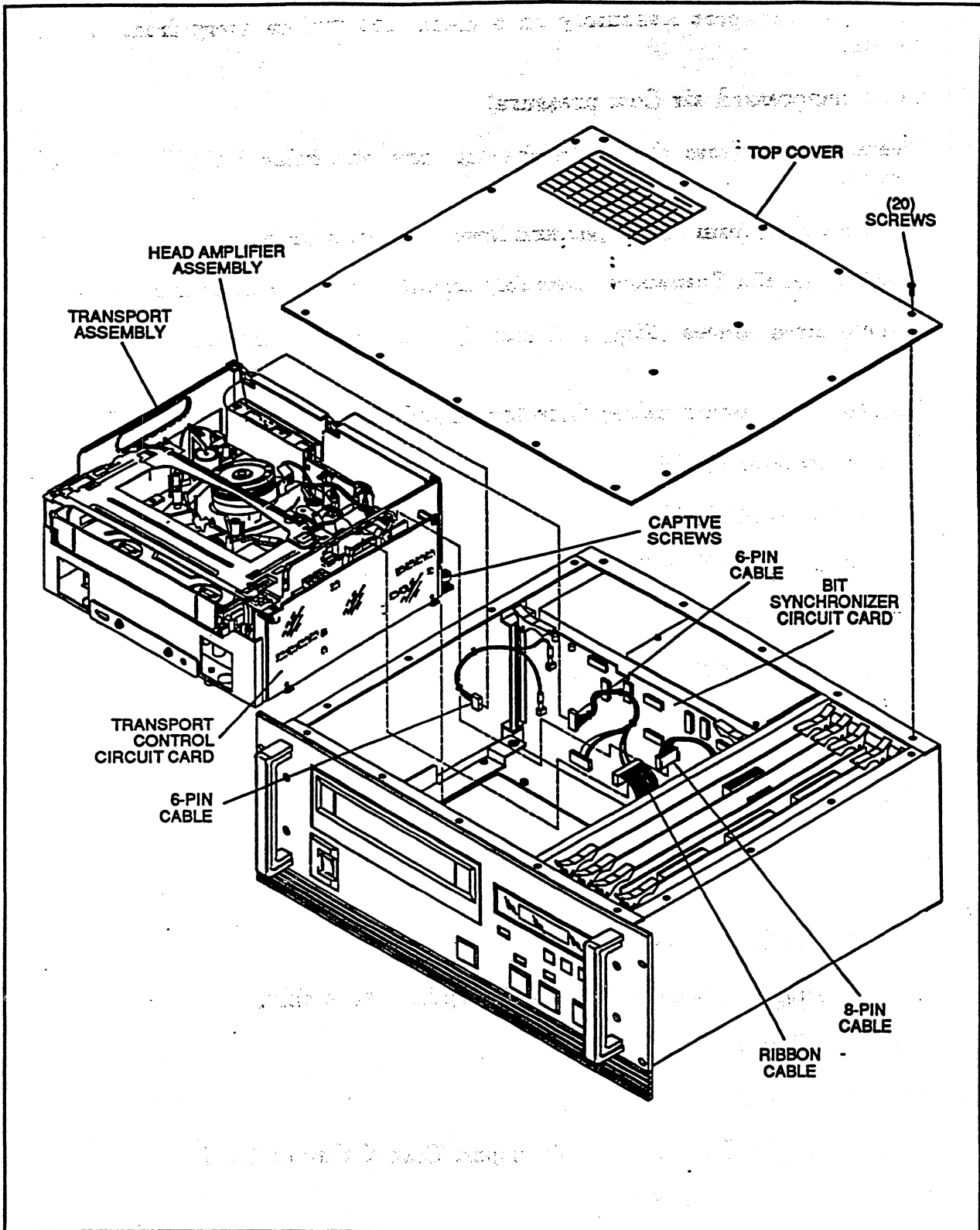

Figure 1. Transport Assembly Removal

9. Place the Transport Assembly on a clean flat surface away from the main chassis.
10. Using compressed air (low pressure)
 - remove dust from the main chassis (pay particular attention to the fan area).
 - remove dust from the upper and lower transport areas.
11. Carefully set the Transport Assembly upside-down on a clean flat surface.
12. Remove three screws (Figure 2, step 1) and carefully lift Servo Circuit Card (hinged).
13. Remove the following cables from the RMJC Circuit Card.
 - 3-pin cable at P1406
 - 3-pin cable at P1405
 - ribbon cable at P1403 (locking type flex connector)
 - 8-pin cable at P1402
 - ribbon cable at P1404 (locking type flex connector)
 - ribbon cable at P1401
14. Remove the RMJC Circuit Card (three screws and lockwasher under ground strap).
15. Remove four screws (refer to Figure 2 step 3) and rotate the gear base to access the gears. **DO NOT REMOVE THE GROUND STRAP SCREW.**
16. Using a disposable towel and/or cloth swabs remove old grease from the following points (see Figure 3). Gears can be moved by physically rotating the loading motor shaft at the belt.
 - Main cam gear slide slot
 - Loading cam gear slide slot.
 - residual grease from slots, plates, and bases.
17. Remove the following cables from the Reel Motor Assembly.
 - 2-pin cable at P1511
 - 2-pin cable at P1510
18. Remove the Reel Motor Assembly (six screws) and place on a clean flat surface.

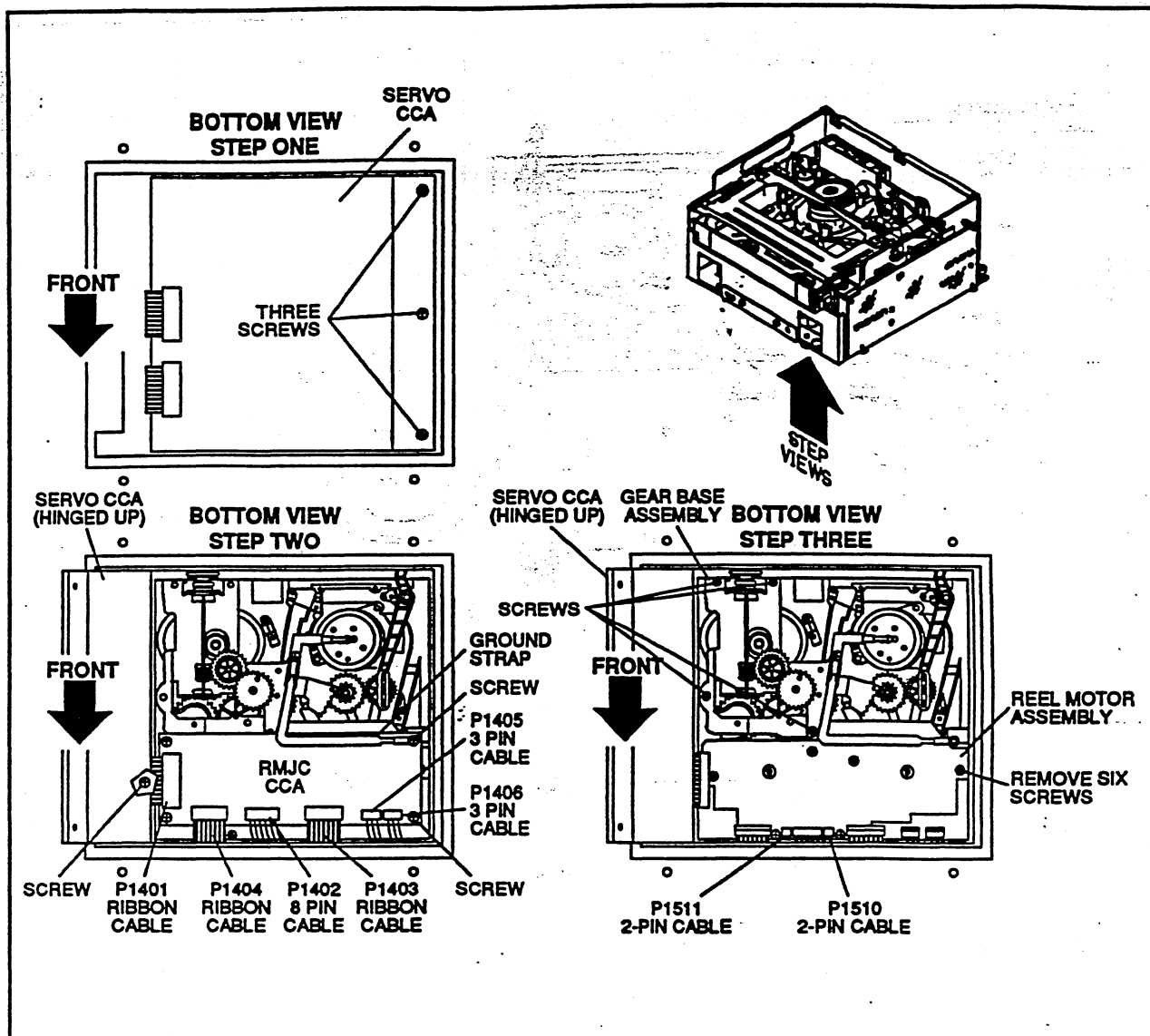

Figure 2. Lubrication Access

19. Release the brake then remove the supply and takeup reels (held on by magnetic field).
20. Using a disposable towel and/or cloth swabs remove old oil from the supply and takeup reel shafts.
21. Using a disposable towel and/or cloth swabs and head cleaning solution, clean the supply and takeup reel hubs (where brakes contact).
22. Apply one or two drops of high quality spindle oil to the supply and takeup reel shafts (see Figure 3).

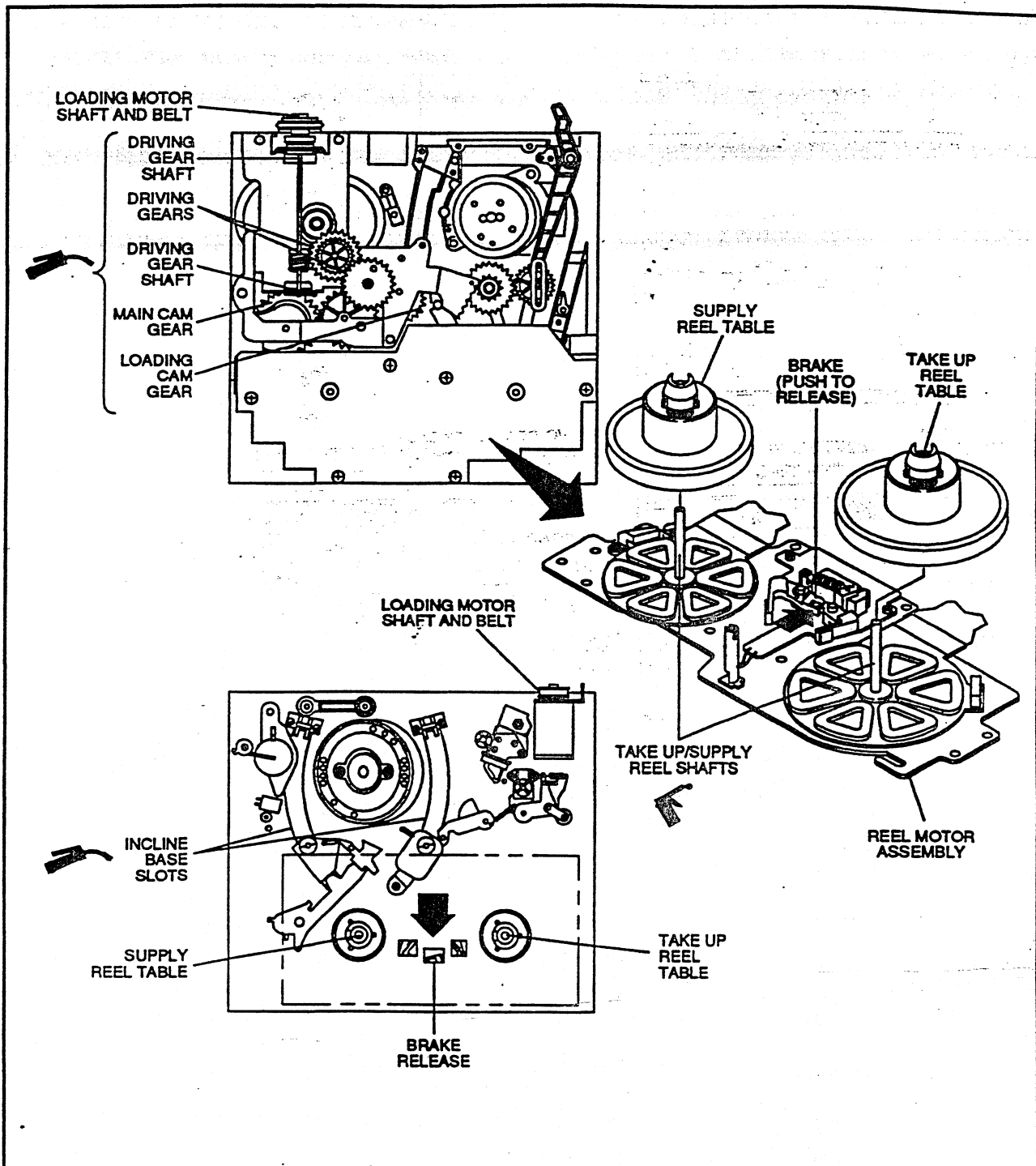

Figure 3. Lubrication Points

23. With the Transport Assembly upside down, use the grease applicator stick to apply Molytone (MOR265) grease to the following points. Gears can be moved by physically rotating the loading motor shaft at the belt. Do not over grease.

- Main cam gear slide slot.
- Loading cam gear slide slot.
- Entire length of both incline base slots (small amount).

24. Carefully place the transport on its side and reinstall the Reel Motor Assembly (reverse steps 17 through 19).

NOTE

While installing the Reel Motor Assembly it is necessary to release (open) the brakes using a small screwdriver (see Figure 3).

25. Reinstall the gear base (four screws) making sure the loading motor belt is in place.
26. Reinstall the RMJC Circuit Card and SERVO Circuit Card (reverse steps 12 through 14).
27. Carefully turn the Transport Assembly over so that the top is facing up.
28. Using a disposable towel and/or cloth swabs remove old grease from both incline base slots. Bases can be moved from the unloaded position by physically rotating the loading motor.
29. Using the grease applicator stick, apply a small amount of Molytone (MOR265) grease to the entire length of both incline base slots. Bases can be moved from the unloaded position by physically rotating the loading motor. Do not over grease.
30. When finished, move bases to the unloaded position (full forward) by rotating the loading motor.

4. TRANSPORT CLEANING

The transport assembly is cleaned using the following instructions. Figure 4 illustrates transport cleaning.

CAUTION

This equipment contains ESDS devices. Proper ESDS device handling procedures must be followed. Refer to the ESDS DEVICE HANDLING information at the front of the User's Guide for more information.

1. Verify that the Transport Assembly has been removed and lubricated using the instructions provided previously.
2. Put on the cotton gloves provided in the maintenance kit.

CAUTION

DO NOT allow the head cleaning cloth or chamois swab to come in direct contact with the scanner EXCEPT as described below. Any other contact can cause permanent damage to the scanner heads.

3. Saturate a CLEAN UNUSED head cleaning cloth with HEAD CLEANING SOLUTION. Place the head cleaning cloth against the scanner drum as shown in Figure 4. DO NOT place the head cleaning cloth or chamois swab directly on the heads.
4. Rotate scanner assembly COUNTERCLOCKWISE (CCW) about three turns while holding the head cleaning cloth in place. This will cause heads to contact cloth in the same manner they contact the tape. DO NOT move the head cleaning cloth while rotating the scanner assembly.
5. Stop rotating the scanner assembly at any point the head cleaning cloth will NOT rest on the heads. Note that the holes on the top of the scanner drum correspond with location of the heads. Remove the head cleaning cloth and inspect for foreign matter.
6. Repeat steps 3 through 5 using CLEAN parts of the head cleaning cloth until no foreign matter is removed from the scanner heads.

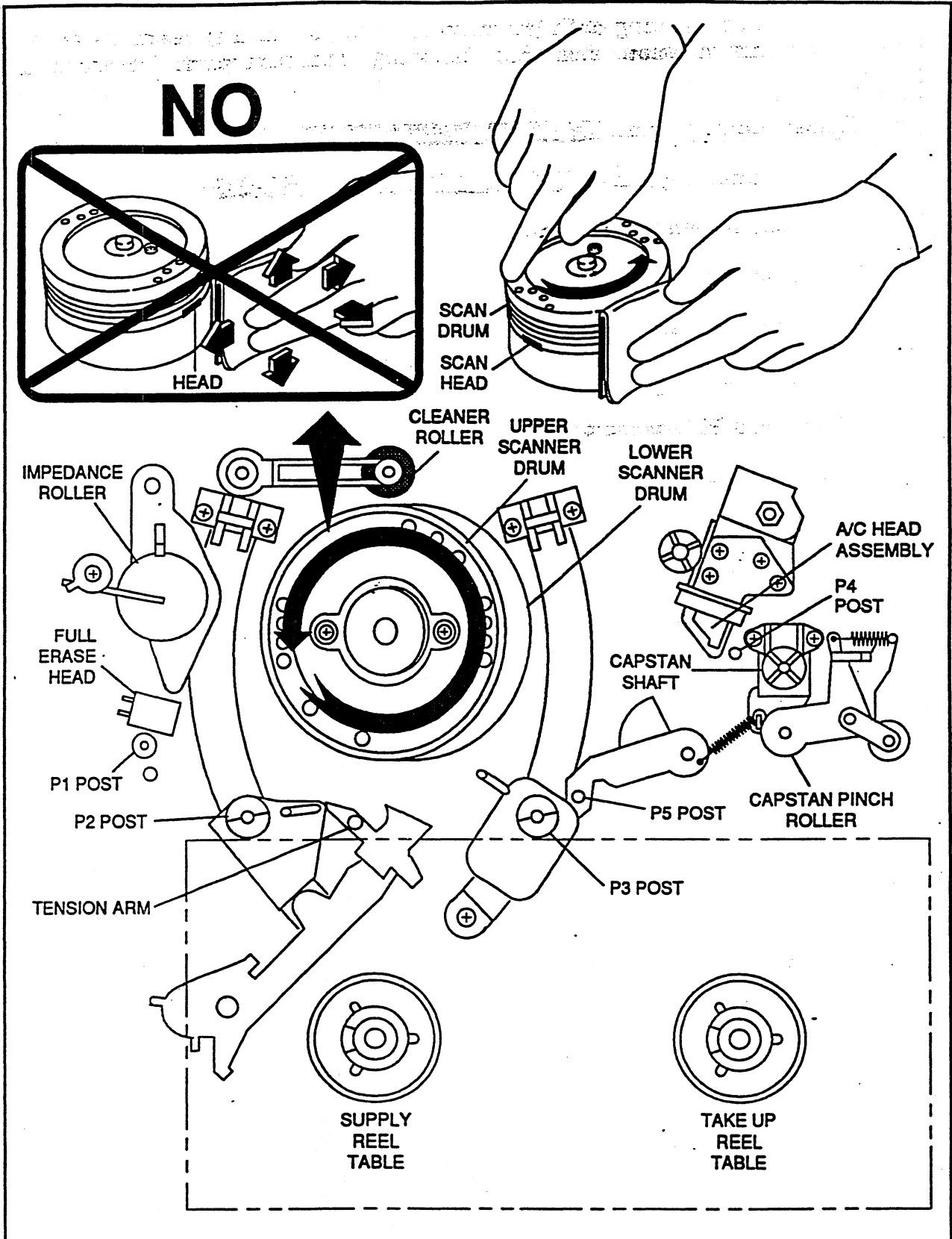

Figure 4. Cleaning Points

7. Using the head cleaning cloth (or chamois swab for hard to reach areas) and head cleaning solution, clean the following transport parts (in the order given):

- Upper scanner drum **(DO NOT CONTACT HEADS)**
- Lower scanner cylinder **(DO NOT CONTACT HEADS)**
- A/C head assembly, all heads
- Full Erase head
- Impedance roller
- Capstan shaft
- P1 through P5 tape guide posts
- Supply reel table
- Takeup reel table
- Tension arm

8. Using a dry clean lint free cloth, clean the transport capstan pinch roller.

CAUTION

DO NOT USE head cleaner on the capstan pinch roller.

9. Using a lint-free soft cotton cloth and head cleaning solution, clean remaining parts (elevator, loader, etc) as required.

5. CLEANING ROLLER REPLACEMENT

The cleaning roller is replaced after the transport has been cleaned and lubricated using the following instructions. Figure 5 illustrates roller replacement.

CAUTION

This equipment contains ESDS devices. Proper ESDS device handling procedures must be followed. Refer to the ESDS DEVICE HANDLING information at the front of the User's Guide for more information.

1. Verify that the transport has been cleaned and lubricated using the instructions provided previously.
2. Disconnect the 2-pin cable from the left side of the Head Amplifier Assembly.
3. Remove two screws and terminal lugs, then pull the Head Amplifier Assembly from the unit (connector is at the bottom).

CAUTION

DO NOT contact scanner heads when removing cleaning roller.

4. Remove cleaning roller assembly (one screw).
5. Remove the old cleaning roller (pull off).
6. Using the cotton gloves provided, install the replacement cleaning roller on the hub making sure that the foam roller is centered between the hub flanges.
7. Install replacement cleaning roller assembly by reversing steps 2 through 4.
8. Reinstall the Transport Assembly and Top Cover (reverse Transport Lubrication steps 1 through 8). Torque screws to 8 kg/cm (maximum).

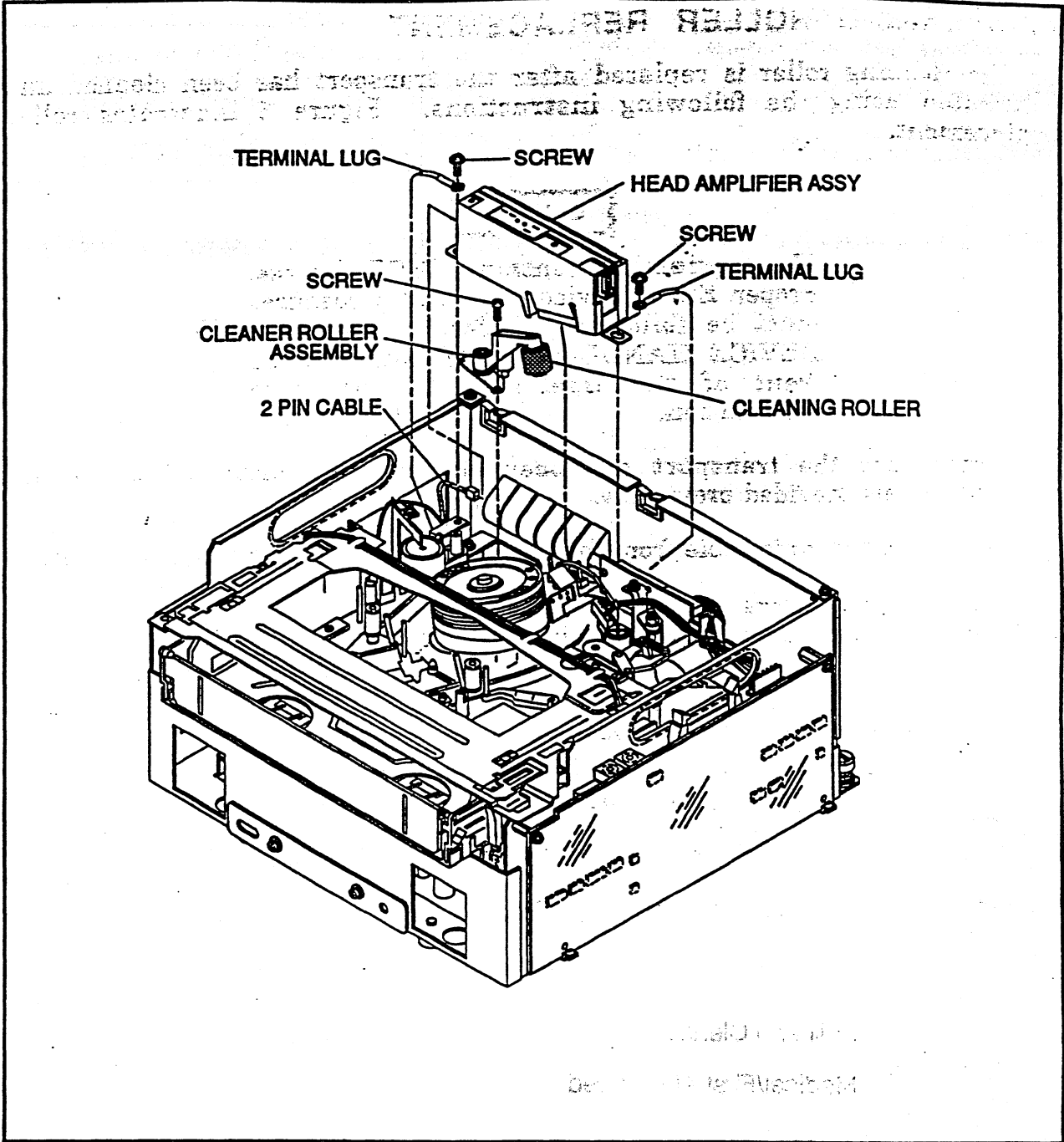

Figure 5. Cleaning Roller Replacement